

Product Line Summary



**LB Series
Lever Hoists**
3/4–9 Ton



**LB-SC Series
Lever Hoists w/ Slip Clutch**
3/4–6 Ton



**LX Series
Mini Pullers**
1/4–1/2 Ton

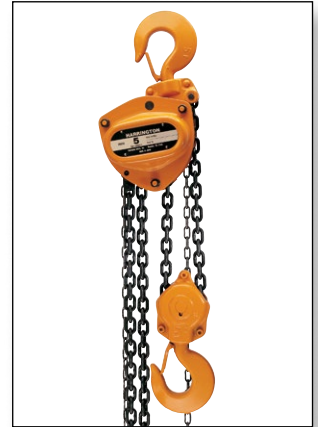

**CB Series
Hand Chain Hoists**
1/2–100 Ton



**CF Series
Hand Chain Hoists**
1/2–5 Ton



**CX Series
Mini Hand Chain Hoists**
1/4–1/2 Ton



**NTH Series
Low Headroom
Hand Chain Hoists
Push Trolleys**
1–5 Ton
(Also G-NTH w/ Geared Trolleys)



**SHB Series
Ultra-Low Headroom
Hand Chain Hoists
Geared Trolleys**
1–10 Ton



**(N)ER Series
Electric Hoists**
3-Phase
1/8–5 Ton



**(N)ER Series
Electric Hoists
Large Capacity**
3-Phase
8–20 Ton



**(N)ERM Series
Electric Hoists
Electric Trolleys**
3-Phase
1/8–5 Ton



**(N)ERM Series
Electric Hoists
Electric Trolleys
Large Capacity**
3-Phase
8–20 Ton

Product Line Summary



**(N)ERP Series
Electric Hoists
Push Trolleys
3-Phase
1/8–5 Ton**



**(N)ERP Series
Electric Hoists
Push Trolleys
Large Capacity
3-Phase
8–10 Ton**



**(N)ERG Series
Electric Hoists
Geared Trolleys
3-Phase
1/8–5 Ton**



**(N)ERG Series
Electric Hoists
Geared Trolleys
Large Capacity
3-Phase
8–20 Ton**



**(N)ER-CC Series
Electric Hoists
3-Phase
Cylinder Control
1/8–1/4 Ton**



**NERM-FG Series
Food Grade Electric Hoists
Electric Trolleys
3-Phase
1/4–2 Ton**



**NERP-FG Series
Food Grade Electric Hoists
Push Trolleys
3-Phase
1/4–2 Ton**



**TNER Theatrical Series
Electric Hoists
3-Phase
1/2–2 Ton**



**SNER Series
Electric Hoists
1-Phase
1/4–3 Ton**



**SNERM Series
Electric Hoists
Electric Trolleys
1-Phase
1/4–3 Ton**



**ED-V/DS/DSA Series
Electric Hoists
1-Phase
Single/Dual Speed
125–1,050 Lbs.**



**ED-DA Series
Electric Hoists
1-Phase
Dual Adjustable
125–525 Lbs.**



AH Series
Air Hoists
Pendant or Cord Control
250–500 Lbs.



AH Series
Air Hoists
Manipulator Control
250–500 Lbs.



TCS Series
Air Hoists
Cord or Pendant Control
1/4–1 Ton



TCR Series
Air Hoists
Cord or Pendant Control
1/4–25 Ton

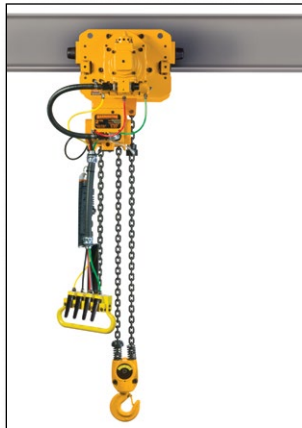

TCRM Series
Air Hoists
Air Trolleys
Pendant Control
1/4–6 Ton



AL Series
Lube Free Air Hoists
Pendant, Cord
or Twist Rod Control
1/4–5 Ton



AW Series
Wash Down Air Hoists
Pendant, Cord
or Twist Rod Control
1/2–1 Ton



AS Series
Spark Resistant Air Hoists
Pendant, Cord
or Twist Rod Control
1/4–1/2 Ton



RHN Series
Electric Hoists
Wire Rope
Deck/Base Mount
2–20 Ton



RHN Series
Electric Hoists
Electric Trolleys
Wire Rope
Ultra-Low Headroom
2–15 Ton



SHLT Series (Static)
DHLT Series (Dynamic)
Hoist Load Testers
1/8–10 Ton



Universal
Beam Clamps
1–10 Ton

Product Line Summary



**Series 3
Motorized End Trucks**
Top: 1–10 Ton
Underhung: 2–5 Ton



**Series 3
Push End Trucks**
Top: 1–5 Ton
Underhung: 2–5 Ton



**Series 3
Geared End Trucks**
Top: 1–5 Ton
Underhung: 2–5 Ton



**HPC Series
Push End Trucks
Top or Underhung
Convertible**
1/2–2 Ton

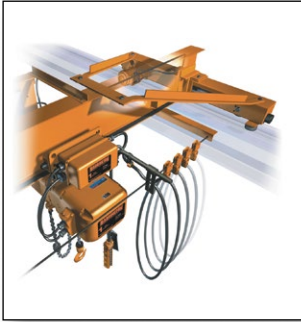

**Series 3
Complete Cranes
Single Girder
Motorized, Push
or Geared
Top**



**Series 3
Complete Cranes
Single Girder
Motorized, Push
or Geared
Underhung**

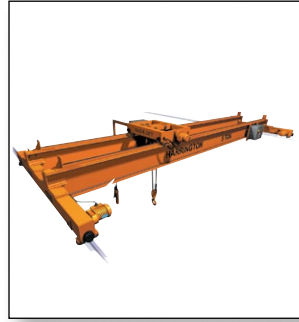

**Series 3
Complete Cranes
Double Girder
Motorized or Geared
Top or Underhung**



**HPC Series
Complete Cranes
Single Girder
Push
Top or Underhung**



**Tiger Track
Jib and Gantry Cranes**



**Below-The-Hook and
Material Handling Equipment**



**PT Series
Push Trolleys**
1/2–10 Ton



**GT Series
Geared Trolleys**
1/2–20 Ton

ORDER FROM
DICK JONES SALES, INC.
PO Box 141, Hanover, PA 17331
P 800-441-9955
F 800-253-4036
dickjones@dickjonesales.com

